

CHAPTER 20: PARKING AND LOADING REGULATIONS

20.01 Purpose

The purpose of this Chapter is to:

- (A) Prevent and alleviate the congestion of public streets;
- (B) Increase and protect the capacity of the roadway system;
- (C) Promote greater safety of passage between highway and land;
- (D) Minimize the detrimental effects of vehicular use areas on adjacent properties; and
- (E) Promote the health, safety, and public welfare by establishing minimum requirements for off-street parking and loading areas as well as provisions for access control.

20.02 Applicability

(A) **New Uses:** The parking, loading, and access control requirements of this Chapter shall apply to a site plan review or zoning permit application for the construction of a new building or use in any district.

(B) **Expanded Uses:**

- (1) Whenever a building or use created prior to the effective date of this Zoning Code is changed or enlarged in floor area, number of units, seating capacity, or otherwise that will create a need for an increase in the number of parking spaces, the additional parking spaces shall be provided on the basis of the new demand created by the enlargement or change.
- (2) If the proposed expansion or enlargement will increase the floor area, number of dwelling units, seating capacity, or other area to an extent larger than twenty (20) percent of the building or use prior to the effective date of this Zoning Code, then the entire site must come into compliance with the requirements of this Chapter.
- (3) In cases where small expansions or enlargements occur over a period of time after the effective date of this Zoning Code, the site shall come into full compliance with the requirements of this Chapter once the total expansion or enlargement of the floor area, number of dwelling units, seating capacity or other area exceeds twenty (20) percent of the original size at the time this Zoning Code became effective.

- (C) **Change of Use:** No change of use shall be authorized unless the new use meets the minimum number of parking spaces required by this Chapter.
- (D) **Existing Uses:** The parking, loading, and access control requirements of this Chapter shall not apply to buildings and uses legally in existence on the effective date of this Zoning Code unless modified in the manner stated in subsections (A) and (B) above. Furthermore, any parking or loading facilities now serving such existing buildings or uses shall not be reduced below the requirements established in this Chapter in the future.
- (E) **Maintenance:** The duty to provide and maintain all such parking and loading areas shall be the joint responsibility of the owner, operator, and lessee of the use for which the vehicular areas are required.

20.03 General Provisions

(A) Parking Plan Required

- (1) Plans for all parking facilities, including parking garages, shall be submitted to the Zoning Inspector for review and a determination of compliance with the provisions of this Zoning Code and other pertinent ordinances of the Village.
- (2) A separate parking plan is not required if the parking plan is being submitted as part of a site plan, in accordance with Chapter 30 (Site Plan Review).

(B) Use of Off-Street Parking Spaces

- (1) Sales, Storage, Repair Prohibited: Any approved off-street parking area shall be used for parking only. Any other use of such space, including, but not limited to, outdoor sales, outdoor storage, repair work or servicing of any kind, other than in an emergency, shall be deemed to constitute a separate commercial use.
- (2) Placement of Vehicles Offered "For Sale" or "For Trade": No person or owner of any vehicle or watercraft shall allow such vehicle to be placed or parked on any public property in the Village zoning jurisdiction, including street rights-of-way, or on any private property zoned for office, commercial, industrial, or service type uses for the purpose of advertising a vehicle "for sale." The provisions of this subsection do not apply to properly licensed motor vehicle dealerships and car lots.

20.04 Off-Street Parking Requirements

(A) Required Number of Parking Spaces

- (1) Parking Spaces Required: Table 20.1 (Schedule of Required Parking by Use) defines the number of parking spaces required for each use within the Village of Maineville.
- (2) Single-Family and Two-Family Residential Uses in All Districts: For single-family and two-family dwellings, the number required by Table 20.1 (Schedule of Required Parking by Use) shall be interpreted as a minimum requirement. Additional parking spaces above the minimum may be provided.

(3) All Other Uses in All Other Districts

- (a) For all uses other than single-family and two-family residential, the number of parking spaces required in Table 20.1 (Schedule of Required Parking by Use) may be modified according to the following provisions without requiring a variance:
 - (i) An applicant may provide a number of spaces equal to the number of spaces required by Table 20.1 (Schedule of Required Parking by Use);
 - (ii) An applicant may provide up to twenty (20) percent fewer than the number of spaces required by Table 20.1 (Schedule of Required Parking by Use); or
 - (iii) An applicant may provide up to ten (10) percent more than the number of spaces required by Table 20.1 (Schedule of Required Parking by Use).
- (b) Applicants may propose fewer parking spaces than provided in subsection (ii) above through the use of shared parking pursuant to subsection (C) (Shared Parking), shadow parking pursuant to Section subsection (E) (Shadow Parking), or may submit an application for a variance in which case the applicant shall provide the BZA with a parking demand study that illustrates the need for the decrease in parking provided.
- (c) Applicants may propose more spaces than allowed in subsection (iii) above but must submit an application for a variance and the applicant shall provide the BZA with a parking demand study that illustrates the need for the increase in parking provided. Additional landscaping requirements may be imposed as a condition by the BZA to alleviate the effect of increased parking.

(B) Rules for Computation of Required Number of Parking Spaces

(1) Location of Parking Spaces

- (a) Parking spaces shall be located on the same lot as the principal use they serve unless the spaces meet the requirements of subsection (C) (Shared Parking) and/or subsection (D) (Off-Site Parking).
 - (b) On-street parking spaces may be counted toward off-street parking space requirements in the B-2 (Downtown Core) District provided the on-street parking spaces are located within three hundred (300) feet of the lot. In all other zoning districts, on-street parking spaces shall not be counted toward off-street parking space requirements.
- (2) Driveway Spaces: Entrances, exits, or driveways shall not be computed as part of the required area for off-street parking spaces, except in the case of single-family and two-family dwellings where driveways may be used in calculating the amount of off-street parking.

VILLAGE OF MAINEVILLE ZONING ORDINANCE

(3) Fractions: When a measurement of the number of required spaces results in a fractional number, any fraction of ½ or less shall be rounded down to the next whole number and any fraction of more than ½ shall be rounded up to the next higher whole number.

(4) Multiple Uses: Unless otherwise noted or approved, off-street parking areas serving more than one use shall provide parking in an amount equal to the combined total of the requirements for each use.

(5) Area Measurements

(a) Unless otherwise specifically noted, all square footage-based parking standards shall be computed on the basis of gross floor area of all floors in a nonresidential building.

(b) Up to twenty five (25) percent of the gross floor area may be excluded from the above calculation if the area is used for storage, loading, unloading, or for mechanical equipment.

(6) Occupancy- or Capacity-Based Standards

(a) For the purpose of computing parking requirements based on employees, students, residents, or occupants, calculations shall be based on the largest number of persons working on single shift, the maximum enrollment, or the maximum fire-rated capacity, whichever is applicable, and whichever results in a greater number of parking spaces.

(b) In hospitals, bassinets shall not be counted as beds.

(c) In the base of benches, pews and similar seating accommodations, each eighteen (18) inches thereof shall be counted as one (1) seat for the purpose of determining the parking requirements.

(7) Unlisted Uses

(1) Upon receiving an application for a use not specifically listed in the parking schedule below, the Zoning Inspector shall apply the parking standard specified for the listed use that is deemed most similar to the proposed use in regards to use, size, and intensity of use.

(2) If the Zoning Inspector determines that there is no listed use similar to the proposed use, intensity, or size, he or she may refer to the estimates of parking demand based on recommendations of the Institute of Traffic Engineers (ITE).

VILLAGE OF MAINEVILLE ZONING ORDINANCE

TABLE 20.1: SCHEDULE OF REQUIRED PARKING BY USE

Use	Parking Spaces Required
AGRICULTURAL USES	
<u>All Agricultural Uses</u>	<u>No parking requirement</u>
RESIDENTIAL USES	
<u>Single Family Dwellings</u>	<u>2 spaces per dwelling unit, exclusive of any garage spaces</u>
<u>Two Family Dwellings</u>	<u>2 spaces per dwelling unit, exclusive of any garage spaces</u>
<u>Multiple Family Dwellings</u>	<u>1.5 spaces per efficiency or single-bedroom dwelling unit and 2 spaces per dwelling unit for multiple bedroom dwelling units</u>
<u>Upper Story Residential</u>	<u>1.5 spaces per efficiency or single-bedroom dwelling unit and 2 spaces per dwelling unit for multiple bedroom dwelling units</u>
<u>Adult Family Homes or Small Residential Facilities</u>	<u>1.5 spaces per bedroom</u>
<u>Adult Group Homes or Large Residential Facilities</u>	<u>1.5 spaces per bedroom</u>
<u>Nursing/Convalescent Homes and Assisted Living Facilities</u>	<u>1 space per 2 beds</u>
<u>Manufactured Home Parks</u>	<u>2 spaces per dwelling unit</u>
PUBLIC AND INSTITUTIONAL USES	
<u>Active Parks, Playgrounds, and Ball Fields</u>	<u>1 space per 10,000 square feet of park or playground area; 20 spaces per ball field</u>
<u>Cemeteries</u>	<u>1 space per 4 seats in a chapel or place of assembly</u>
<u>Churches and Places of Worship</u>	<u>1 space per 3 fixed seats in the main assembly room or 1 space per 3 persons, whichever is greater</u>
<u>Educational Institutions</u>	<u>3 spaces per classroom, 1 space per 4 seats in auditorium, or 1 space for each 17 classroom seats (at maximum capacity), whichever is greater</u>
<u>Educational Institutions, Higher</u>	<u>1 space for each 5 classroom seats plus 1 space for each auditorium seat</u>
<u>Fraternal Organizations or Social Clubs</u>	<u>1 space per 1,000 square feet or 1 space per 2 persons, whichever is greater</u>

VILLAGE OF MAINEVILLE ZONING ORDINANCE

TABLE 20.1: SCHEDULE OF REQUIRED PARKING BY USE

Use	Parking Spaces Required
<u>Police or Fire Station</u>	<u>No parking requirement</u>
<u>Government Facilities</u>	<u>1 space per 350 square feet or 1 space per 4 people at maximum occupancy, whichever is greater</u>
<u>Hospitals and Outpatient Centers</u>	<u>1 space for every 2 patient beds plus outpatient clinics, laboratories, pharmacies and other similar uses shall have 4 spaces per 1,000 square feet</u>
<u>Libraries or Cultural Centers</u>	<u>1 space per 350 square feet</u>
<u>Passive Parks, Open Space, and Conservation Areas</u>	<u>1 space per 10,000 square feet of park or playground area; or none if found acceptable by the Zoning Inspector due to the use's passive nature</u>
<u>Public Infrastructure</u>	<u>No parking requirement</u>
<u>Public Utilities</u>	<u>No parking requirement</u>
<u>Telecommunication Facilities (New Facility/Tower)</u>	<u>1 space per structure</u>
COMMERCIAL USES	
<u>Adult Entertainment Facilities</u>	<u>1 space per 300 square feet</u>
<u>Banquet/Assembly Halls or Conference Centers</u>	<u>1 space per 2 persons, or 1 per 1,000 square feet, whichever is greater</u>
<u>Automobile Body Repair Shops</u>	<u>1 space per 250 square feet of office space plus 2 spaces per service bay (service bays excluded as parking)</u>
<u>Automobile Fueling Stations</u>	<u>1 space per 350 square feet (excluding required stacking spaces at fuel pumps)</u>
<u>Automobile General Repair</u>	<u>1 space per 250 square feet of office space plus 2 spaces per service bay (service bays excluded as parking)</u>
<u>Automobile Oil Change, Lube, or Light Service</u>	<u>1 space per 250 square feet of office space plus 2 spaces per service bay (service bays excluded as parking)</u>
<u>Automobile Sales or Rental Establishments</u>	<u>1 space per 400 square feet of showroom and/or office space plus 2 spaces per service bay (service bays excluded as parking)</u>
<u>Automobile Washing Facility</u>	<u>2 drying spaces per lane (See also required stacking spaces)</u>

VILLAGE OF MAINEVILLE ZONING ORDINANCE

TABLE 20.1: SCHEDULE OF REQUIRED PARKING BY USE

Use	Parking Spaces Required
<u>Bars, Brewpubs and Taverns</u>	<u>1 space per 100 square feet</u>
<u>Clinics</u>	<u>1 space per 250 square feet</u>
<u>Convenience Stores</u>	<u>1 space per 250 square feet</u>
<u>Day Care Centers</u>	<u>1 space for every 4 children</u>
<u>Drive-Through Facilities</u>	<u>2 spaces for drive-through employees (does not include stacking spaces)</u>
<u>Equipment Sales and Leasing</u>	<u>1 per 250 square feet of indoor floor space plus 1 space per 500 square feet of outdoor sales or display area</u>
<u>Family Day Care – Type A (7-12 children)</u>	<u>2 spaces for the owner/unit plus 1 space for each 3 children who do not live in the dwelling</u>
<u>Family Day Care – Type B (1 to 6 children)</u>	<u>2 spaces for the owner/unit plus 1 space for each 3 children who do not live in the dwelling</u>
<u>Financial Institutions</u>	<u>1 space per 250 square feet</u>
<u>Flea Markets</u>	<u>1 space per 300 square feet of indoor sales area and 1 space per 500 square feet of outdoor sales area</u>
<u>Funeral Homes</u>	<u>1 space per 75 square feet of parlor or chapel space</u>
<u>Garden Centers</u>	<u>1 per 300 square feet plus 1 per 1,500 square feet of outdoor sales or display area</u>
<u>Hotels or Motels</u>	<u>1 space per room or suite</u>
<u>Kennels or Animal Shelters</u>	<u>1 space per 1,000 square feet</u>
<u>Marijuana Dispensary</u>	<u>1 space per 300 square feet</u>
<u>Micro-breweries, Micro-distilleries, or Micro-wineries</u>	<u>1 space per 100 square feet of tasting room, taproom or table service area</u>
<u>Moving Truck and Trailer Rental</u>	<u>1 per 250 square feet of floor area</u>

VILLAGE OF MAINEVILLE ZONING ORDINANCE

TABLE 20.1: SCHEDULE OF REQUIRED PARKING BY USE

Use	Parking Spaces Required
Offices and Professional Services	1 space per 350 square feet
Parking Lots or Garages	No parking requirement
Personal Service Establishments	1 space per 200 square feet, or 2 spaces per station/chair, whichever is greater
Recreational Facility (Indoor)	5 spaces per 1,000 square feet of a skating rink; 5 spaces per bowling lane; 5 spaces per racquetball court; otherwise, 2 spaces per 1,000 square feet
Recreational Facility (Outdoor)	8 spaces per golf hole; 2 spaces per golf driving range tee; 2 spaces per miniature golf hole; 5 spaces per play court; 20 spaces per ball field; 20 spaces per 1,000 square feet of swimming pool area
Retail and Service Uses	1 space per 250 square feet
Restaurants	1 space per 100 square feet
Self-Storage Facilities	1 space per 80 storage units
Shooting Range (Indoor)	2 spaces per target area
Shooting Range (Outdoor)	2 spaces per target area
Theaters	1 space per 2 fixed seats or 1 space per 2 persons based on the maximum occupancy, whichever is greater
Truck Stops	1 space per 350 square feet (not including truck parking spaces)
Veterinary Clinics or Animal Grooming	1 space per 250 square feet
INDUSTRIAL USES	
All Industrial Uses	1 for each employee computed on the basis of the greatest number of persons to be present at any one period during the day or night

(C) Shared Parking: For combinations of land uses, the Planning Commission may grant a reduction in the required number of required parking spaces when multiple uses with offsetting peak hours of parking demand are provided on the same lot, as follows:

TABLE 20.2: SHARED PARKING REDUCTIONS	
<u>Number of Uses</u>	<u>Maximum Reduction</u>
<u>4+</u>	<u>30%</u>
<u>3+</u>	<u>15%</u>
<u>2+</u>	<u>10%</u>

- (1) Churches and other places of worship may share up to 100% of their required parking spaces.
- (2) Theaters and other places of assembly may share up to 50% of their required parking spaces.
- (3) Documentation must be provided that the land uses involved have peak hours of parking demand that do not overlap.
- (4) A written agreement shall be drawn to the satisfaction of the Village Solicitor and executed by all parties assuring the continued availability of the shared parking facilities for the use they are intended to serve.

(D) Off-Site Parking

- (1) All or a portion of the required off-street parking spaces, as determined per Table 20.1 (Schedule of Required Parking by Use), may be located on an adjacent or nearby property, so long as no parking space is located more than five hundred (500) feet from the primary entrance of the use served, measured along the shortest legal, practical walking route. This route may include crossing a right-of-way provided it uses a legal crosswalk.
- (2) Off-site parking shall not be used to satisfy the off-street parking requirements for single-family dwellings, two-family dwellings, and hospitals. Required parking spaces reserved for persons with disabilities shall not be located in an off-site parking facility, unless waived by the Planning Commission if proper safety measures and compliance with ADA requirements can be demonstrated.
- (3) In the event that an off-site parking area is not under the same ownership as the principal use served, a written agreement shall be required. An off-site parking agreement shall include evidence of deed restrictions or other recorded covenants that ensure that the spaces will be properly maintained during the life of the development. All off-site parking agreements shall be recorded in the office of the Warren County Recorder and a copy of the recorded document shall be provided to the Zoning Inspector prior to any zoning permit being issued.

(E) Shadow Parking: Up to thirty (30) percent of the required off-street parking spaces, as determined per Table 20.1 (Schedule of Required Parking by Use), may remain landscaped and unpaved, or paved with pervious pavers, provided that the parking and unpaved areas are authorized in accordance with subsection (A)(3) and comply with the following standards:

- (1) The parking plan submitted with the Zoning Permit or Site Plan Review application shall denote the location and layout of that portion of the parking area that currently is no longer deemed required. The plan shall indicate that the "shadow" parking spaces will be constructed according to this Zoning Code in event that the Zoning Inspector makes a finding, at any time, that all or any portion of this parking is necessary.
- (2) At no time shall any portion of the required parking area that is so designated for future construction be used for the construction of any structure or paved surface with the exception that pervious pavers may be used to provide temporary parking provided that the pavers allow for grass and other vegetation to grow through the material.
- (3) At no time shall any portion of the required parking or loading area that is so designated for future construction as provided herein be counted as open space or other non-paved areas required by other provisions of this Zoning Code.
- (4) The owner shall initiate construction of the approved "future" parking area, as identified on the approved parking and loading plan, within three (3) months of the receipt of a certified letter or a letter through normal postal service (in the event that the certified letter is not accepted) sent to the owner of record from the Zoning Department, identifying that such parking is determined to be necessary.

FIGURE 20.1: SHADOW PARKING

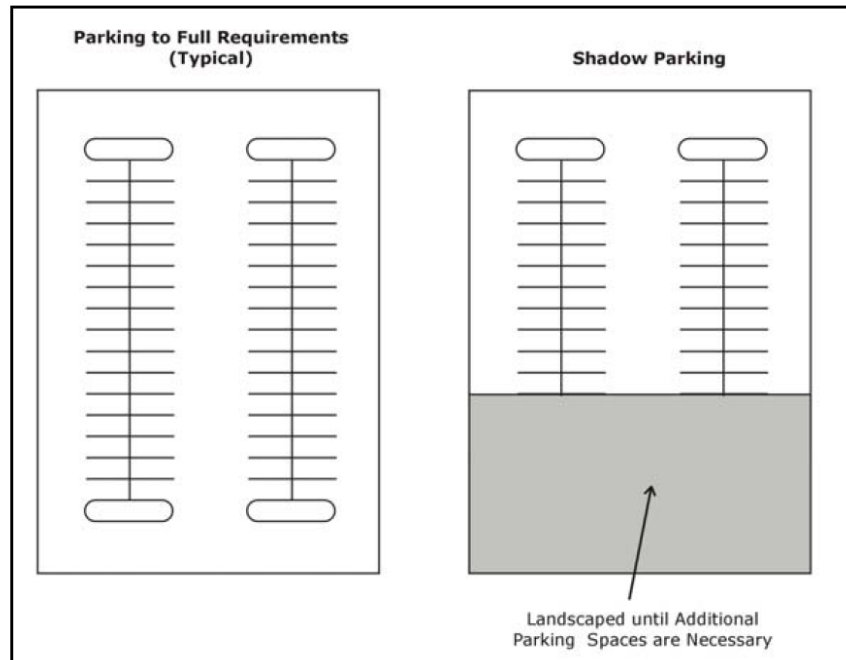

20.05 Vehicle Stacking Requirements

(A) Required Number of Parking Spaces

The number of required stacking spaces shall be provided as established in [Table 20.4](#) and [Figure 20.2](#).

TABLE 20.4: MINIMUM VEHICLE STACKING SPACE REQUIREMENTS

<u>Activities/Uses</u>	<u>Minimum Stacking Spaces (per lane)</u>	<u>Measured From (and including)</u>
<u>Financial Institutions or Automated Teller Machine (ATM)</u>	<u>3</u>	<u>Teller or Window</u>
<u>Restaurant</u>	<u>8</u>	<u>First Pick-Up Window</u>
<u>Full Service Car Wash</u>	<u>20 / 12 *</u>	<u>Entrance of Tunnel / Exit of Tunnel</u>
<u>Self-Service or Automated Drive-Through Car Wash</u>	<u>4</u>	<u>Washing Bay</u>
<u>Fuel or Gasoline Pump Island</u>	<u>2 *</u>	<u>Pump Island</u>
<u>Other</u>	<u>As determined by Zoning Inspector *</u>	

VILLAGE OF MAINEVILLE ZONING ORDINANCE

* **Full Service Car Wash:** The 20 spaces required prior to the entrance of the tunnel may be spread across multiple stacking lanes. The 12 stacking spaces shall be required outside of the exit of the wash tunnel to provide areas for the drying of cars, vacuuming, or other ancillary services.

* **Fuel or Gasoline Pump Island:** Pump spaces can count toward the stacking requirement.

* **Other:** Any other use shall be required to document proof that the provided number and location of stacking spaces are adequate to meet the purpose of this Section.

FIGURE 20.2: VEHICLE STACKING

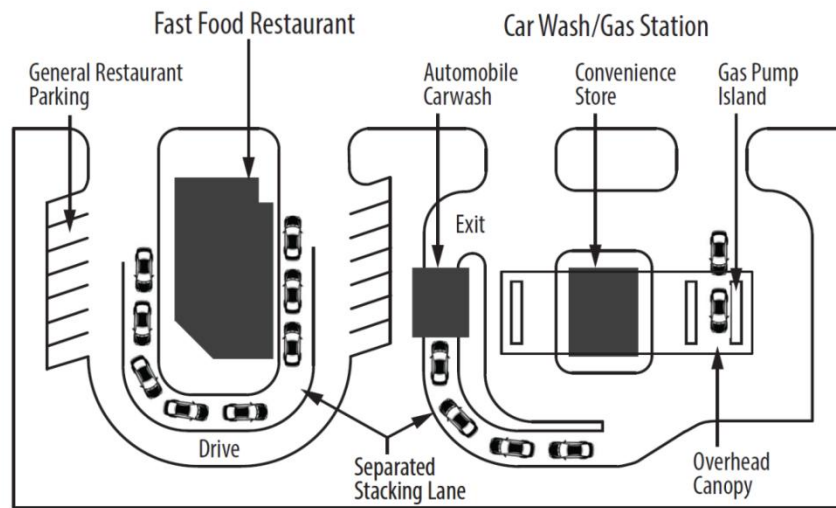

(B) Design and Layout

- (1) Stacking spaces shall be a minimum of ten (10) feet by twenty (20) feet in size.
- (2) Stacking spaces may not impede on- or off-site traffic movements or movements in or out of off street parking spaces.
- (3) Stacking spaces shall be separated from other internal driveways by surface markings or raised medians.
- (4) These stacking spaces requirements shall be in addition to the off-street parking space requirements.
- (5) When adjacent to a residential zoning district, or any lot used for residential purposes, stacking spaces shall be required to be located on sides of the lot opposite the adjacent residential use.

20.06 Off-Street Loading Requirements

- (A) General Requirements:** Each building, structure, or use shall be designed to provide and shall provide for off-street loading in the minimum amounts specified in this Section.

VILLAGE OF MAINEVILLE ZONING ORDINANCE

Loading spaces shall not conflict or overlay with the area used for parking spaces or parking aisles.

(B) Required Number of Off-Street Loading Spaces: The minimum number of loading spaces provided for various uses shall be as follows in Table 20.5.

TABLE 20.5: MINIMUM LOADING SPACE REQUIREMENTS		
<u>Activities/Uses</u>	<u>Building Floor Area (Square Feet)</u>	<u>Minimum Loading Spaces Required</u>
<u>Public buildings; educational, religious, and philanthropic institutions; hospitals or other institutions, places of assembly or for sports or athletics; clubs; lodges; multiple family dwellings; and similar uses</u>	<u>0 – 100,000</u>	<u>1</u>
	<u>Each additional 100,000</u>	<u>1</u>
<u>Banks and financial institutions; medical offices and clinics; administrative, business, and professional offices; dancing or other commercial schools; theaters; bowling alleys; skating rinks; or other places of amusement and recreation</u>	<u>0 – 100,000</u>	<u>1</u>
	<u>Each additional 100,000</u>	<u>1</u>
<u>Retail stores; eating and drinking places; and all other commercial uses</u>	<u>0 – 10,000</u>	<u>1</u>
	<u>10,001 – 30,000</u>	<u>2</u>
	<u>30,001 – 50,000</u>	<u>3</u>
	<u>50,001 – 100,000</u>	<u>4</u>
<u>Light and heavy industrial uses</u>	<u>Each additional 100,000</u>	<u>1</u>
	<u>0 – 20,000</u>	<u>1</u>
	<u>20,001 – 40,000</u>	<u>2</u>
	<u>40,001 – 60,000</u>	<u>3</u>

(C) Dimension of Loading Spaces: Loading spaces shall be at least twelve (12) feet in width and twenty-five (25) feet in length with a vertical clearance of at least fourteen (14) feet in height.

(D) Location of Loading Spaces:

(1) Loading spaces shall not be provided in the front yard or on any building façade facing or visible from a public street, except where the Planning Commission determines such a location is necessary due to the location or placement of the building, existing street patterns, or other factors.

VILLAGE OF MAINEVILLE ZONING ORDINANCE

(2) No loading space shall be closer than one hundred (100) feet to any residential use or district, unless wholly within a completely enclosed building or unless enclosed on all sides by a wall or uniformly painted solid board fence not less than six (6) feet in height.

(3) In all other cases, loading spaces shall be set back a minimum of ten (10) feet from all property lines.

(4) No loading space shall be in a designated fire lane.

(E) Access

(1) Loading spaces shall be designed and arranged to provide access to a street or alley in a manner that will create the least possible interference with traffic movement and parking lot circulation. The Zoning Inspector shall approve access to and from loading spaces.

(2) No part of any truck or van that is being loaded or unloaded may extend into the right-of-way of a public thoroughfare.

(3) Loading spaces shall be designed with sufficient apron area to accommodate truck-turning movements and to prevent backing of trucks onto any street right-of-way.

20.07 Design Standards for Vehicular Use Areas

The following standards shall apply to the design and construction of off-street parking, loading, and stacking spaces and areas unless otherwise noted.

(A) Dimensions

(1) The minimum size of a parking space may be altered based on aisle width and angle of parking. Parking stalls and aisle width shall conform to the minimum standards set forth in Table 20.6 and Figure 20.3.

TABLE 20.6: PARKING AREA DIMENSIONS				
<u>Angle of Parking</u>	<u>One-Way Maneuvering Aisle Width</u>	<u>Two-Way Maneuvering Aisle Width</u>	<u>Parking Stall Width</u>	<u>Parking Stall Length</u>
<u>0° (Parallel)</u>	<u>13 feet</u>	<u>20 feet</u>	<u>9 feet</u>	<u>23 feet</u>
<u>30° - 53°</u>	<u>13 feet</u>	<u>20 feet</u>	<u>10 feet</u>	<u>19 feet</u>
<u>54° - 75°</u>	<u>18 feet</u>	<u>22 feet</u>	<u>10 feet</u>	<u>19 feet</u>
<u>76° - 90°</u>	<u>24 feet</u>	<u>24 feet</u>	<u>10 feet</u>	<u>18 feet</u>

FIGURE 20.3: PARKING AREA DIMENSIONS

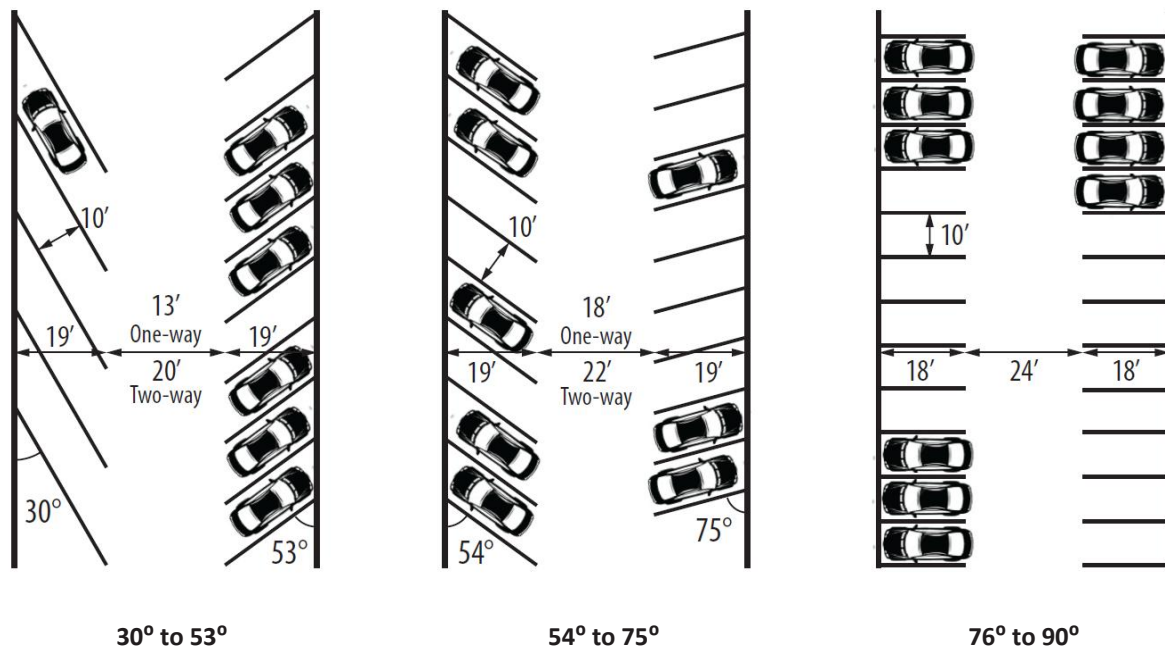

(2) Parking areas may include compact car parking spaces provided that the parking spaces shall be a minimum of eight (8) feet in width and fourteen (14) feet in length. Such parking for compact cars shall not be included in the calculations for required parking.

(B) Surface Material: All off-street parking areas and driveways shall be surfaced with asphalt concrete, or Portland Cement concrete so as to provide a durable and dustless surface and proper disposal of stormwater. Off-street parking facilities shall also be paved in accordance with the construction and design standards established by the Village.

(C) Pavement Markings

(1) Designated parking spaces, drive aisles, and pavement markings shall be marked on the surface of paved parking areas with paint or permanent marking materials and maintained in a clearly visible condition.

(2) Where driveways intersect the public right-of-way, the paint lines dividing vehicle paths and other pavement markings shall be in accordance with the State of Ohio Uniform Traffic Control Manual.

(D) Curbs and Wheel Stops

(1) For all non-residential and multi-family development, continuous curbs are required on the outside of all vehicular use areas and landscaped islands, subject to the following standards:

- (a) Curbing shall be made of concrete, stone, or other similar material and shall have a minimum height of six (6) inches and a minimum width of six (6) inches.
 - (b) Curbing shall be located a minimum of two (2) feet from any structures, buildings, walls, or plant material (excluding ground cover) to prevent a vehicle from hitting any structure or driving through landscaped areas at the edge of a parking area.
 - (c) Curbing requirements may be waived by the Planning Commission if parking islands and/or areas beyond the parking lot can adequately accommodate storm water runoff through an alternate method such as the use of rain gardens with interrupted curbs. Wheel stops (see illustration below) shall be provided for parking spaces where no curb is present.
- (2) If wheel stops are to be used in the parking area, each wheel stop shall be a singular block of reinforced concrete, or similar material typical for such purpose (see illustration below). Wheel stops are to be securely attached to the ground and may be used only at the end of parking stalls. Wheel stops may be attached no less than two (2) feet from the rear edge of the parking space.

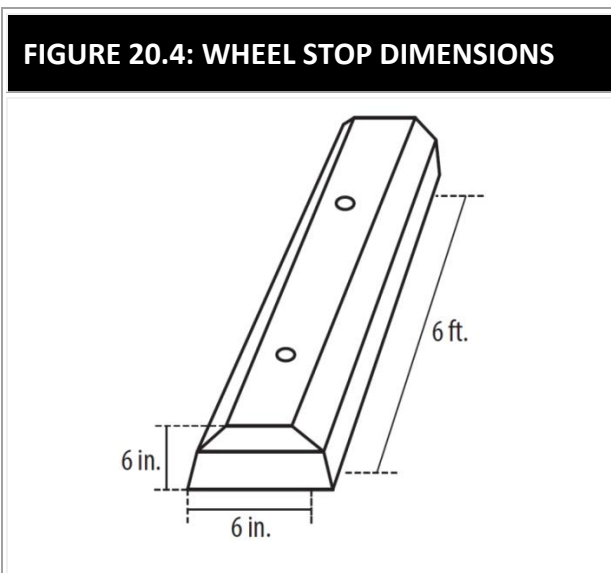

- (E) Drainage: All parking and loading areas shall provide for proper drainage of surface water to prevent the drainage of such water onto adjacent properties or walkways.
- (F) Parking Requirements for the Disabled: Applicants shall provide parking spaces for the physically disabled as required by the Ohio Building Code and shall include all necessary marking, striping, and signage.
- (G) Fire Code: All parking and loading plans shall conform to all requirements set forth in the Fire Code as approved by the Maineville Fire Department.

- (H) Interior Landscaping: Vehicular use areas for ten (10) vehicles or more shall be landscaped in accordance with the provisions of Chapter 29 (Landscaping and Screening).
- (I) Setback Requirements: All driveways shall be located at least two (2) feet from side or rear property lines for all single-family and two-family residential properties and ten (10) feet for all other land uses, excepting cases where a shared driveway with an associated access easement straddles two or more properties served by the driveway. Development within the B-2 (Downtown Core) District shall also be exempt from these requirements.
- (J) Access Requirements: All required off-street parking or loading spaces shall be connected with a deeded public right-of-way by means of aisles or access driveways. Shared ingress and egress is strongly encouraged for multi-family and non-residential uses whenever possible. To the maximum extent feasible, provisions for primary access along secondary streets shall be provided to minimize traffic congestion on primary arterial streets.

20.08 Walkway Connections to Public Sidewalks

- (A) Where a sidewalk exists in a public right-of-way adjacent to the site, or is required to be constructed as part of the development approval, a pedestrian connection shall be constructed from the building to the sidewalk.
- (B) Stand alone pedestrian connections shall be constructed of concrete or hard surface pavers.
- (C) The pedestrian connection shall have a minimum width of four (4) feet.

20.09 Proper Maintenance

The owner of property used for parking and/or loading shall maintain such area in good condition, without holes and free of all dust, trash, and other debris.

20.10 Parking of Commercial Vehicles

- (A) Owners and/or operators of vehicles exceeding two (2) tons may be parked for a period not to exceed forty-eight (48) hours within a seven (7) day period.
- (B) Vehicles are not permitted to remain idling.
- (C) Any type of commercial vehicle, regardless of gross vehicle weight, delivering or picking up merchandise for delivery, or employed in performance of repair or a construction service, may park for the purpose of making such pick up or delivery, or for the duration of the period during which a repair or construction service is being performed on or to property in the area where parked.